



**SURE FLAME<sup>®</sup>**

# SL11E & S1500E CONSTRUCTION HEATERS



Rev: 4.3; January 11, 2013

**SERVICE AND MAINTENANCE MANUAL No. 974-9307  
PLEASE RETAIN FOR FUTURE REFERENCE**

**SURE FLAME<sup>®</sup> PRODUCTS**

A DIVISION OF HAUL-ALL EQUIPMENT LTD.

4115 - 18 Avenue North  
Lethbridge, Alberta T1H 5G1  
[www.sureflame.com](http://www.sureflame.com)

## SL11E & S1500E Construction Heaters



### GENERAL HAZARD WARNING

Failure to comply with the precautions and instructions provided with this heater, can result in death, serious bodily injury and property loss or damage from hazards of fire, explosion, burn, asphyxiation, carbon monoxide poisoning, and/or electrical shock.

Only persons who can understand and follow the instructions should use or service this heater.

If you need assistance or heater information such as an instruction manual, labels, etc. Contact the manufacturer.



### WARNING

Fire, burn, inhalation, and explosion hazard. Keep solid combustibles, such as building materials, paper or cardboard, a safe distance away from the heater as recommended by the instructions. Never use the heater in spaces which do or may contain volatile or airborne combustibles, or products such as gasoline, solvents, paint thinner, dust particles or unknown chemicals.



### WARNING

Not for home or recreational vehicle use

# **READ THIS WARNING FIRST!**

The heater is designed and approved for use as a construction heater under CAN 2.14-2000. The primary purpose of construction heaters is to provide temporary heating of buildings under construction, alteration, or repair and to provide temporary emergency heat. Properly used the heater provides safe economical heating. Products of combustion are vented into the area being heated.

The heater is not designed as an Unvented Gas Fired Room Heater under ANSI-Z21.11.2 and should not be used in the home.

ANSI A119.2(NFPA 501C)-1987 Recreational Vehicle Standard prohibits the installation or storage of LP-Gas containers even temporarily inside any recreational vehicle. The standard also prohibits the use of Unvented Heaters in such vehicles.

**Gas inspection authorities in Canada require that the installation and maintenance of heaters and accessories be accomplished by qualified gas fitters.**

**Installation must comply with the Natural Gas and Propane Installation Code, CSA B149.1.**

We cannot anticipate every use which may be made for our heaters. CHECK WITH YOUR LOCAL FIRE SAFETY AUTHORITY IF YOU HAVE QUESTIONS ABOUT LOCAL REGULATIONS.

Other standards govern the use of fuel gases and heat producing products in specific applications. Your local authority can advise you about these.

## **FOR YOUR SAFETY**

**DO NOT USE THIS HEATER IN A SPACE WHERE  
GASOLINE OR OTHER LIQUIDS HAVING  
FLAMMABLE VAPOURS ARE STORED OR USED.**

# SL11E & S1500E CONSTRUCTION HEATERS

## Contents

Specifications .....	5
Installation .....	6
Installation Using A Propane Supply Tank .....	7
Installation For Natural Gas Applications .....	7
Operating Instructions .....	8
Common Installation And Operational Problems .....	9
Safety Controls .....	9
Design Related Additional Safety Features .....	10
On-Site Hazards .....	10
Preventive Maintenance .....	11
Troubleshooting .....	12
Replacement Parts .....	20
SL11E Connection Wiring Diagram .....	22
SL11E Ladder Wiring Diagram .....	23
S1500E Connection Wiring Diagram .....	24
S1500E Ladder Wiring Diagram .....	25
Two-Stage Thermostat Wiring Diagram .....	26
LPG - Propane Fuel Vaporization Rate .....	27
Maximum Btu Content (Propane) .....	27
Pressure & Flow Equivalents .....	27

# Specifications

CSA certified to 2.14-2000 Construction Heater

Gases:		Natural or Propane
Capacity:	SL11E	1,000,000 Btu/h (290 kW) Maximum
	S1500E	1,500,000 Btu/h (440 kW) Maximum 850,000 Btu/h (250 kW) Minimum
Orifice Size:		41 DMS x 46
Blower:		7,000 cfm (12,000 m <sup>3</sup> /h)
Electrical Rating:		115 volts, 60 Hz, 9.4 amps, Single Phase

Min Temperature Rating: - 40 Degrees F/C

## Gas Supply: SL11E

	Inlet Pressure		Manifold Pressure
	Max.WC(Pa)	Min.WC(Pa)	Max. WC(Pa)
Propane	14" (3500)	8" (2000)	1.8" (450)
Natural	14" (3500)	8" (2000)	4.8" (1200)

(Minimum inlet pressure is for purpose of input adjustment)

## Gas Supply: S1500E

	Inlet Pressure		Manifold Pressure	
	Max.WC(Pa)	Min.WC(Pa)	Max.WC(Pa)	Min.WC(Pa)
Propane	14" (3500)	8" (2000)	2.7" (670)	0.75" (190)
Natural	14" (3500)	8" (2000)	7.2" (1800)	2.0" (500)

# Installation

The Sure Flame Models SL11E & S1500E are direct fired gas heaters intended to be used primarily for the temporary heating of buildings under construction, alteration, or repair. Since all the products of combustion are released into the area being heated, it is imperative that adequate ventilation be provided. The flow of supply air and combustion gases must not be obstructed in any way. Do not use the heater with ductwork as this will restrict the flow of supply air.

- 1 Install the heater in a horizontal position at least 10 feet (3M) from any LP-gas container, and allow the following clearance from any combustible materials:

Front Outlet:	20 feet (6 M)	Sides:	2 feet (0.6 M)
Intake:	2 feet (0.6 M)	Top:	4 feet (1.2 M)

Front Outlet must not be directed at any LP-gas container within 20 feet (6M).

Also make sure that no flammable vapours are present in the space where the heater is being used.

- 2 When connecting the heater to a natural gas or propane supply line ensure that the pressure at the heater inlet is within the specified range. Excessive pressure (over 1/2" psig) will damage the controls and void the warranty.
- 3 Visually inspect the hose assembly and ensure that it is protected from traffic, building materials, and contact with hot surfaces. If it is evident that there is excessive abrasion or wear, or the hose is cut, it must be replaced.
- 4 After installation, check the hose assembly for gas leaks by applying a water and soap solution to each connection.
- 5 Connect the heater to an adequate 115 volt electrical supply as specified on the rating plate. For protection against shock hazard the supply cord must be plugged directly into a properly grounded three-prong receptacle.
- 6 In all applications install the heater in such manner that it is not directly exposed to water spray, rain and/or dripping water.

## **Installation Using A Propane Supply Tank**

- 1 When installing the heater for use with propane gas, set the gas selector valve to “Propane” and lock in position.
- 2 The supply container must be equipped with a UL listed Gas Pressure Regulator. This is essential to reduce the gas pressure to a safe transmittable pressure. This pressure must further be reduced so the gas pressure does not exceed the maximum input pressure of the heater. This can be accomplished by placing a suitably sized second stage gas regulator on the valve train at the heater. This regulator should also be a UL listed LP Gas Pressure Regulator.
- 3 Arrange the propane supply system to provide for vapour withdrawal from the operating container. Supplying liquid propane to the heater is dangerous and will damage the components.
- 4 Ensure that for the surrounding temperature the size and capacity of the propane supply container is adequate to provide the rated Btu/h input to the heater.
- 5 Turn off the propane supply valve at the container when the heater is not in use.
- 6 The installation must conform with local codes, or in the absence of local codes, with the Natural Gas and Propane Installation Code, CSA B149.1.
- 7 When the heater is to be stored indoors the propane container must be disconnected from the heater and the container moved away and stored in accordance with the above national standard.

## **Installation For Natural Gas Applications**

- 1 When installing the heater for use with natural gas, set the gas selector valve to the “Natural” position.
- 2 A regulator must be installed on the heater to ensure that the pressure to the heater does not exceed 1/2 psi inlet pressure.
- 3 The installation of this heater to a natural gas supply must conform with all applicable local codes or, in the absence of local codes, with the CAN/CGA-B149.1 Natural Gas Installation Code.

# Operating Instructions

1. Set GAS SELECTOR VALVE to gas being used. The conversion shall be done by the owner or lessor of the equipment.

**Warning:** When using propane gas, the GAS SELECTOR VALVE must be locked in position.

2. Ensure the FIRING VALVE is in the "ON" position.
3. Connect power cord to a 115 volt supply.
4. Open gas supply.
5. If equipped with a thermostat, set the thermostat to the desired temperature.
6. Push START Button. After a short delay, the heater will start.

Note: The SL11E, if equipped with a thermostat, will cycle between on and off as required.

Note: The S1500E will cycle between high flame, low flame, and off as required.

7. To stop: push STOP button. If the heater is to remain off, disconnect power cord, and close gas supply.

The appliance area should be kept clear and free from combustible materials, gasoline, and other flammable vapours and liquids.

Ensure that the flow of supply air and combustion gases is not obstructed.

The installation and operation of the heater shall comply with the code requirements specified by the authorities having jurisdiction.

General criteria for the use of construction heaters may be found in the applicable sections of the Natural Gas and Propane Installation Code, CSA B149.1.

**THE INSTALLATION AND MAINTENANCE OF THE  
HEATER MUST BE ACCOMPLISHED  
BY A QUALIFIED SERVICE PERSON.**



# Common Installation And Operational Problems

## 1 LOW VOLTAGE

This is one of the most common problems and is usually the result of the supply cord having too small of a wire gauge for its length. Low voltage results in the motor overheating, burnt relay contacts, or a relay that will not maintain contact.

## 2 SUPPLY LINE TOO SMALL

## 3 INSUFFICIENT VAPORIZATION AT SUPPLY

Normally caused by too small size of supply tank.

## 4 IMPROPER GAS SUPPLY PRESSURE

Usually a result of supply pressure being too high because of improper or lack of regulation.

## 5 DIRTY GAS SUPPLY

Dirty gas can cause strainers to plug or form a build-up in the burner orifice.

## 6 LACK OF PREVENTATIVE MAINTENANCE

Heaters must be cleaned as required, especially when used in a dirty environment.

## 7 IMPROPER SUPPLY OF FRESH AIR

Recommended: Intake air for the heater be taken from outside the enclosed area. This provides a slight pressurization and prevents any problems associated with recirculation.

## Safety Controls

Servicing of Sure Flame Construction Heaters normally involves one of several built-in safety features. The Models SL11E & S1500E incorporate devices to detect the following:

### 1 LOSS OF FLAME

Gas supply is shut off if flame is lost to prevent raw gas from leaving the heater.

### 2 OVERHEATING

(a) Thermal overload protection in the motor.

(b) High temperature limit switch in the combustion chamber.

### 3 LOSS OF POWER

Total shutdown with manual reset required. Any one of the safety devices will create a loss of power situation.

### 4 BLOCKED AIR SUPPLY

A switch detects the differential pressure in the combustion chamber and shuts down when insufficient.

## **Design Related Additional Safety Features**

### **1 LOCKING POSITION FOR LPG ON GAS SELECTOR LEVER**

Units used with LPG while the gas selector valve is positioned for Natural Gas will throw significantly more heat than the rated Btu/h. This is definitely a safety hazard.

### **2 LOW SKIN TEMPERATURE**

Sure Flame Heaters are designed to have a low skin temperature. This provides added safety in the workplace.

### **3 DURABLE CONSTRUCTION**

The Models SL11E & S1500E use a stainless steel burner for long life and consistent performance.

In order to maintain the highly efficient combustion of the Sure Flame Heater, the combustion chamber must remain as manufactured. Any change or distortion could alter the fuel/air mixture and create hazardous gases.

## **On-Site Hazards**

### **1 SHORTING OUT OF DEFECTIVE COMPONENTS**

This is a common problem which saves short term expense at the risk of a large future cost. Any heaters found in this condition should be removed immediately.

### **2 IMPROPER ENCLOSURES**

When heaters are installed partially to the outside for fresh air intake, strict adherence must be made to the minimum clearance to combustibles given on the instruction plate. Wood framing around a heater is a request for trouble.

### **3 SUPPLYING LIQUID PROPANE TO HEATER**

This problem has occurred from time to time. To minimize the damage, and possible personal injury, shut off the gas supply and let the heater run until all of the liquid in the lines has been vaporized.

## Preventive Maintenance

Sure Flame Construction Heaters are built to withstand the rigours of operating on construction sites, for mining applications, and a multitude of other locations where heaters are used. To maintain the reliable performance required it is necessary to do a certain amount of regular maintenance.

### A. VISUAL CHECKS

The following items should be checked for excessive wear or damage:

- 1) Wheels
- 2) Cords and Connectors
- 3) Wiring and Conduit
- 4) Heater Shell (including heat shield) and Control Box
- 5) Valve Train

It is recommended that units purchased as spares be rotated periodically, so that each unit will be placed in operation at least once every 90 days.

### B. BURNER

Flame Rod and Insulator - Clean with soap and water or solvent on a routine basis. Any build up on burner should also be removed at this time.

Ground Wire - Ensure that the ground wire is secured to the burner. This is necessary for the flame detection system to operate.

Spark Plug - Clean with solvent and check spark gap. The gap should be set to 1/8".

### C. CONTROL BOX

The inside of the control box should be cleaned using a dry cloth or by blowing compressed air. Do not use any liquid or aerosol spray cleaners. Also check that all electrical connections are snug and tight.

### D. MOTOR

The electric motor on the SL11E & S1500E Heaters is fitted with sealed bearings and no oiling is required. Keep the motor clean by blowing or wiping off dust or dirt in order to prevent it from over heating.

### E. FAN

Check for dust or dirt build up on fan blades. Check the tightness of the set screw and run the heater to check for fan vibration.

## Troubleshooting

The troubleshooting section has been divided in to six tables. Choose the appropriate table from the list below:

Chart A – Heater does not start, fan does not start

Chart B – Heater does not start, fan starts, no spark, no flame

Chart C – Heater does not start, fan starts, spark, no flame

Chart D – Heater starts, flame lights but goes out after a few seconds

Chart E – Heater starts, but fails during operation

Chart F – Other problems

**Chart A – Heater does not start, fan does not start**

Symptom	Possible Causes	Indicators Outside Control Box					Indicators Inside Control Box					Flame Control LED	
		Green Start Switch	Red Stop Switch	Thermostat Power Light †	Thermostat Stage 1 Light †	Thermostat Stage 2 Light †	L2	L6	L7	L8	L12		
Green start light does not come on when start switch is pressed.	No electrical supply	off	off	off	off	off	off	off	off	off	off	off	off
	Stop switch fails open	off	off	off	off	off	on	off	off	off	off	off	off
	Start switch fails open	on/off	off	off	off	off	on	off	off	off	*	off	off
Green start light comes on when pressed, but goes off when released. L12 flashes when start switch released.	Fuse failure	on/off	off	off	off	off	on	off	off	off	off	off	Off
	Reset switch fails open	on	off	off	off	off	on	off	off	off	off	off	Off
	Thermostat stage 1 fails open †	on	off	-	-	-	on	off	off	off	off	off	off
Green start light is on, but red stop light remains off during attempts to start.	Flame control failure – Power in	on	off	on	-	-	on	off	off	off	off	off	off
	Flame control failure – Thermostat in †	on	off	on	on	-	on	off	off	off	off	off	off
	Flame control failure – Motor out	on	on	on	on	-	on	off	off	off	off	off	*
	Motor relay fails open	on	on	on	on	-	on	on	off	off	off	off	*
	Motor failure	on	on	on	on	-	on	on	off	off	off	off	*
Green start light is on, red stop light comes on during attempts to start	Low Voltage (long extension cord or too many items on circuit). Motor relay may chatter.	on	on	on	on	-	on	*	*	*	*	off	off
	Air switch fails closed	on	on	on	-	-	on	off	off	off	off	off	*

† Thermostat is optional on model SL11E

Chart B – Heater does not start, fan starts, no spark, no flame	Symptom	Possible Causes	Indicators Outside Control Box					Indicators Inside Control Box					
			Green Start Switch	Red Stop Switch	Thermostat Power Light †	Thermostat Stage 1 Light †	Thermostat Stage 2 Light †	L2	L6	L7	L8	L12	Flame Control LED
Air blowing through heater in reverse.		Motor wired incorrectly	on	on	on	un	-	on	off	off	off	off	*
No gas odor at heater outlet. L7 light is off. Voltage between N2 and L15 is 120V during attempt to start.		Air tubes set in wrong position Air switch fails open Air switch set to too high a pressure Air tubes plugged	on	on	un	un	-	on	off	off	off	off	*
No gas odor at heater outlet. L7 light is off. Voltage between N2 and L15 is 0V during attempt to start.		Strainer plugged or dirty Too small of a hose, too long of a hose, blocked hose Too low of inlet pressure Second stage regulator set too low Propane tank too small to vapourize fast enough, tank freezes Upstream regulators installed backwards Flame control failure – Air in Flame control failure – spark out	on	on	un	un	-	on	off	off	off	off	*
No gas odor at heater outlet. L7 light is on.		Flame control failure – spark out	on	on	on	on	-	on	on	on	on	off	*
Gas odor at heater outlet. L7 light on. L8 light on, then off.		Spark plug fails Flame rod and spark plug wires reversed Spark plug wire damaged	on	on	on	on	-	on	on	on	on	on/off	***

† Thermostat is optional on model SL11E

**Chart C – Heater does not start, fan starts, spark, no flame**

Symptom	Possible Causes	Indicators Outside Control Box					Indicators Inside Control Box					
		Green Start Switch	Red Stop Switch	Thermostat Power Light †	Thermostat Stage 1 Light †	Thermostat Stage 2 Light †	L2	L6	L7	L8	L12	Flame Control LED
No gas odor at heater outlet. L8 light is off. Voltage between N2 and L17 is 120V during attempt to start.	Limit switch fails open	on	on	on	on	on	on	on	on	off	off	***
No gas odor at heater outlet. L8 light is off. Voltage between V1 and V2 on flame controller is 0V during attempt to start.	Flame control failure	on	on	on	on	on	on	on	on	off	off	***
No gas odor at heater outlet. L8 light is on, then off.	Manual valve closed Solenoid valve fails closed Too high of inlet pressure. Second stage regulator set too high. (This may cause the 2-stage regulator to be damaged)	on	on	on	on	on	on	on	on/off	off	off	***
Gas odor at heater outlet. L8 light on, then off.	2-stage regulator installed backwards Burner orifices plugged or dirty Spark plug gap too large (weak spark) or too small. Gap should be set to 1/8 inch. Low flame regulator setting too low	on	on	on	on	on	on	on	on/off	off	off	***

† Thermostat is optional on model SL11E

**Chart D – Heater starts, flame lights but goes out after a few seconds**

Symptom	Possible Causes	Indicators Outside Control Box							Indicators Inside Control Box				
		Green Start Switch	Red Stop Switch	Thermostat Power	Light †	Thermostat Stage 1 Light †	Thermostat Stage 2 Light †	L2	L6	L7	L8	L12	Flame Control LED
Connect DC current meter with microampere range to terminals FC+ and FC- of the flame controller. Start heater. Check reading once flame is established. Reading is 1.0 microamperes or higher Reading from above is less than 1.0 microamperes.	Flame control failure – Flame sensing	on	on	on	on	-	on	on	on	on	on/off	off	***
	Flame rod dirty, cracked, or otherwise defective.	on	on	on	on	-	on	on	on	on	on/off	off	***
	Flame rod wire loose or damaged Burner not grounded	on	on	on	on	-	on	on	on	on	on/off	off	***

† Thermostat is optional on model SL11E



**Chart E – Heater starts, but fails during operation**

Symptom	Possible Causes	Indicators Outside Control Box						Indicators Inside Control Box					
		Green Start Switch	Red Stop Switch	Thermostat Power	Light †	Thermostat Stage 1 Light †	Thermostat Stage 2 Light †	L2	L6	L7	L8	L12	Flame Control LED
Normal flame length prior to failure. Three flashes on flame control LED.	Low Voltage (long extension cord or too many items on circuit)	on	on/off	on			on	on/off	on/off	off	off	off	***
Smaller than normal flame prior to failure. Single flash on flame control LED.	Propane tank too small to vapourize fast enough, tank freezes Strainer plugged or dirty	on	on	on			on	on	on/off	on/off	off	off	*
Normal flame length prior to failure. Three flashes on flame control LED. Immediately after failure, voltage between N2 and L17 is 120V, between N2 and L16 is 0V.	Limit switch failure – too sensitive	on	on	on			on	on/off	on/off	off	off	off	***
Longer than normal flame before failure, possibly shooting outside of heater body. Three flashes on flame control LED. Immediately after failure, voltage between N2 and L17 is 120V, between N2 and L16 is 0V.	Changeover valve set to natural gas when connected to propane. Connected to liquid propane Too high of inlet pressure Second stage regulator set too high High flame regulator setting too high	on	on	on			on	on/off	on/off	on/off	off	off	***

† Thermostat is optional on model SL11E

**Chart F – Other Problems**

Symptom	Possible Causes	Indicators Outside Control Box						Indicators Inside Control Box						
		Green Start Switch	Red Stop Switch	Thermostat Power Light †	Thermostat Stage 1 Light †	Thermostat Stage 2 Light †	L2	L6	L7	L8	L12	Flame Control LED		
Excessive vibration or noisy operation.	Damaged or unbalanced fan blade	on	off	on	-	-	on	on	on	on	off	off	off	off
Fan motor starts immediately when heater is plugged in, even if thermostat is not calling for heat	Motor relay fails closed	off	off	off	off	off	on	off	off	off	off	off	off	off
Heater will start as soon as it is plugged in. Stop button will reset the heater.	Start switch fails closed	on	off	on	-	-	on	-	-	-	-	-	-	-
Flame length shorter than normal	Low flame regulator setting too low	on	off	on	on	-	on	on	on	on	on	off	off	off
Normal operation except flame length shorter than normal	High flame regulator setting too low	on	off	on	on	on	on	on	on	on	on	off	off	off
Small flame, otherwise functions normally.	Changeover valve set to propane when connected to natural gas	on	off	on	on	-	on	on	on	on	on	off	off	off
Heater will never go to high flame.	Thermostat stage 2 fails open	on	off	on	-	-	on	on	on	on	on	off	off	off
Normal operation, but low flame longer than normal.	Low flame regulator setting too high	on	off	on	on	-	on	on	on	on	on	off	off	off
Gas will flow to burner immediately when supply to heater is opened	Solenoid valve fails open	-	-	-	-	-	-	-	-	-	-	-	-	-
Gas will flow to burner immediately when supply to heater is opened	Solenoid valve leaks	-	-	-	-	-	-	-	-	-	-	-	-	-

† Thermostat is optional on model SL11E



# Replacement Parts

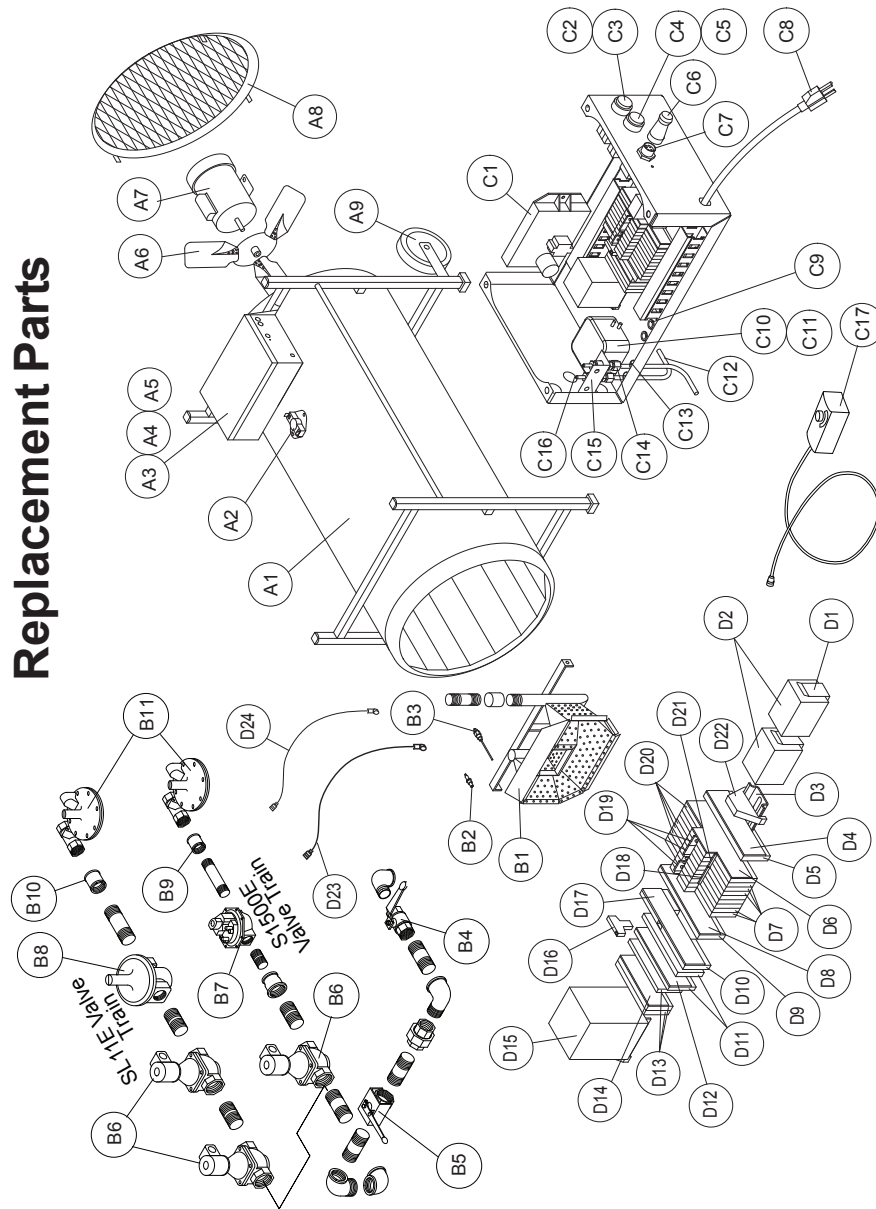

Ref	Part No.	Description	Ref	Part No.	Description
A1	S1505-56	Heater Body	C12	S1500-109	Air Tube
A2	2446	Limit Switch, 180°F	C13	5515	Rubber Grommet
A3	S1500-104	Control Box Lid	C14	2554	Compression Fitting, 1/4" Tubex 1/8" MNPT
A4	S1500-501	Control Box	C15	S1500-502	Air Tube Bracket
A5	7723	Control Box Seal	C16	9348	Brass Elbow
A6	2423	Fan Blade, 24"	C17	S1500-714	2-Stage Thermostat w/Cable (S1500E Only)
A7	9262	Motor, 1HP	D1	9826	Relay Holder Clip
A8	SL11B-53	Screen	D2	9264	Relay
A9	6119	Wheel	D3	S1500-105	DIN Mounting Rail
B1	BV85-50	Burner	D4	4655	End Plate for 4668
B2	2143	Spark Plug	D5	4668	Ground Terminal Block (green)
B3	SL11B-86	Flame Rod	D6	4654	End Plate for 4528
B4	2539	Manual Shut-Off Valve, 1-1/2"	D7	4658	Terminal Block 2P + 2P (gray)
B5	S1505-81	Gas Selector Valve, 1-1/2"	D8	4657	End Plate for 4669
B6	2537	Solenoid Valve, 1-1/2"	D9	4669	Terminal Block 4P (gray)
B7	4490	2-Stage Regulator, 1-1/4" (S1500E Only)	D10	4527	Fused Terminal Block (gray)
B8	2526	1-1/2" Appliance Regulator (SL11E Only)	D11	4529	Terminal Block 3P (gray)
B9	S1500-86	Strainer Assembly, 1-1/4" (S1500E Only)	D12	4524	End Plate for 4529
B10	SL11B-715	Strainer Assembly, 1-1/2" (SL11E Only)	D13	4530	Terminal Block 2P (gray)
B11	2528	Regulator (optional)	D14	4525	End Plate for 4530
C1	9624	Flame Controller	D15	8659	Utility Box
C2	9612	Start Button Assembly	D16	9271	Fuse Holder
C3	S1500-718	Start Contact Block Assembly		9270	Fuse 2A
C4	9611	Stop Button Assembly	D17	4526	End Plate for 4527
C5	S1500-717	Stop Contact Block Assembly	D18	4622	Jumper 5 Pole
C6	S1500-713	Thermostat Jumper Assembly (S1500E Only)	D19	4523	Jumper 2 Pole
C7	8682	Thermostat Receptacle (S1500E Only)	D20	4528	Terminal Block w/Light 2P + 2P (red)
C8	3868	Power Cord, 24"	D21	4652	Jumper 3 Pole
C9	5509	Snap Bushing, 1/2"	D22	9443	Ground Terminal Block (green/yellow)
C10	S1500-710	Adjusted Air Switch	D23	WR4IEX-60	Ignition Wire
C11	1707	Silicone Tubing	D24	WR7BFY-66	Flame Rod Wire

# SL11E Connection Wiring Diagram

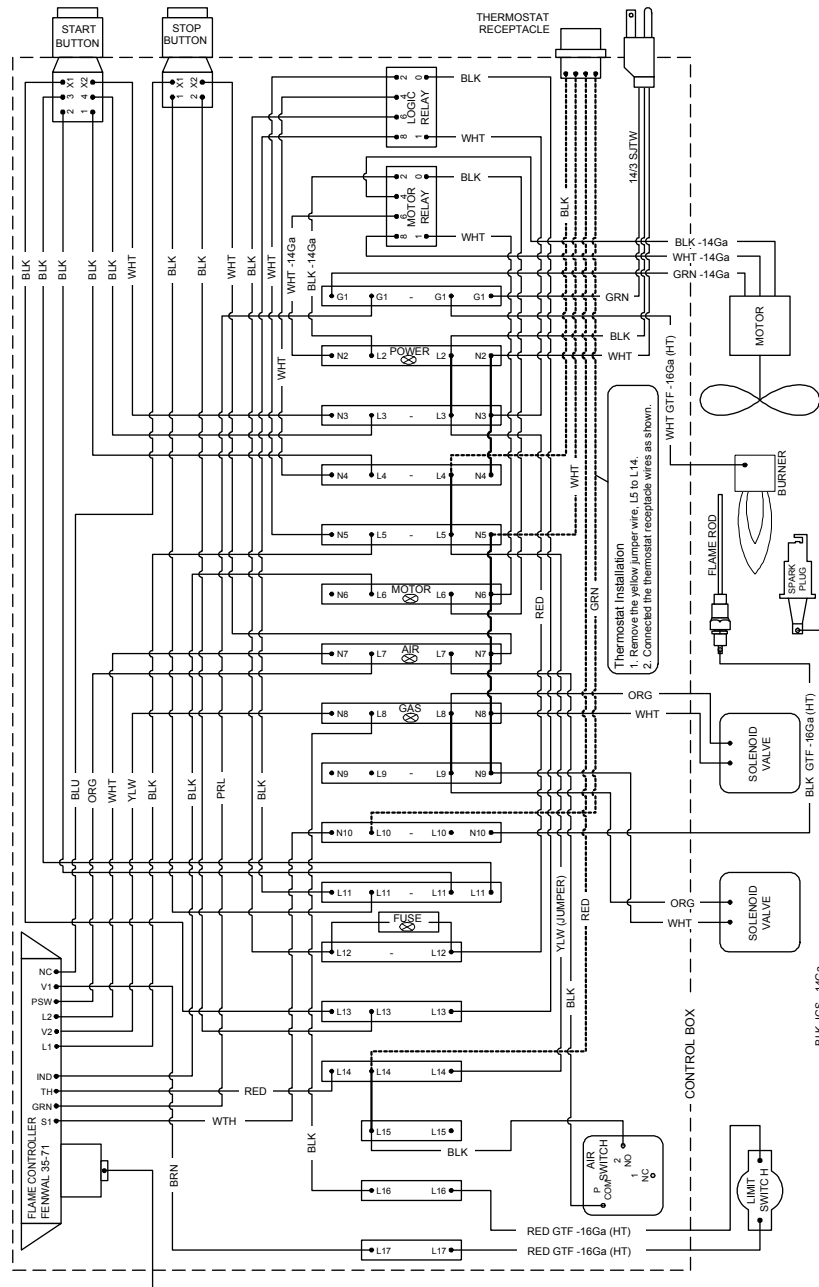

Note: All wires 18 Ga STR TEW 600V unless otherwise specified.

Rev.2.0 From S/N: 2619

# SL11E Ladder Wiring Diagram

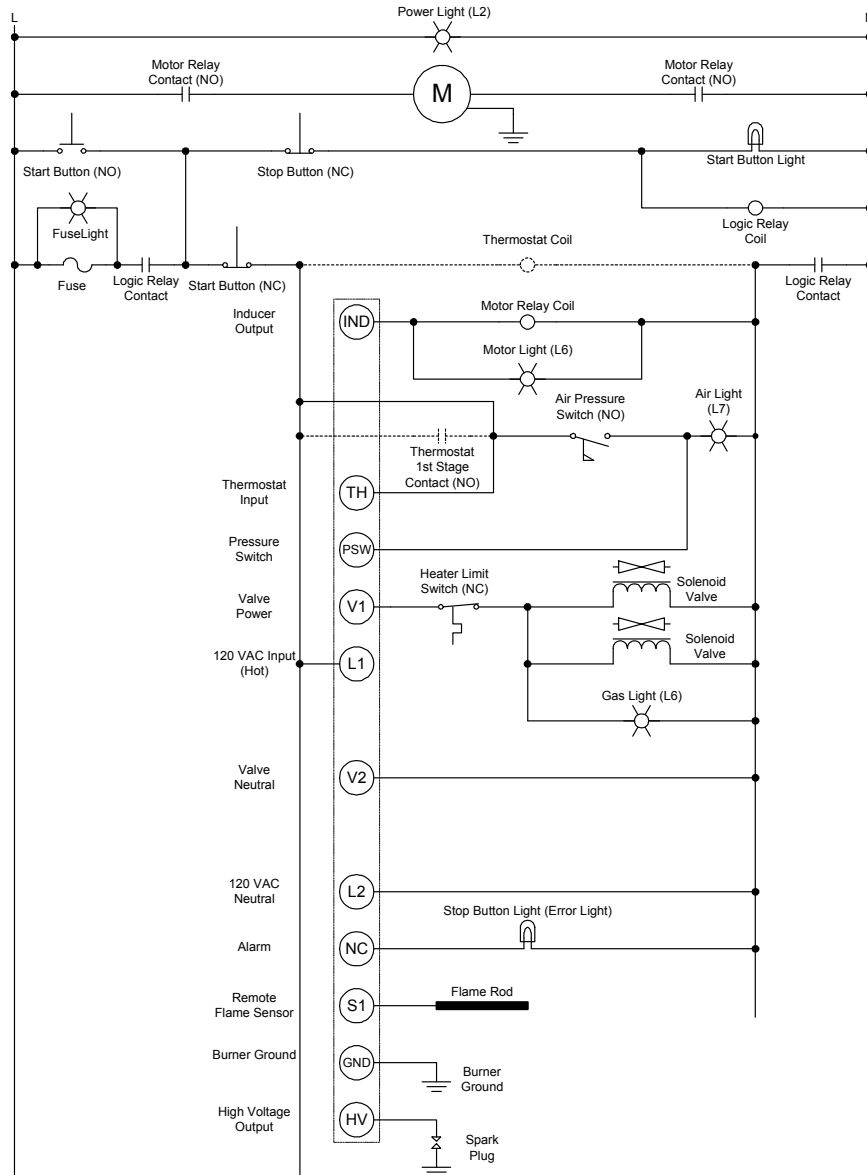

# S1500E Connection Wiring Diagram

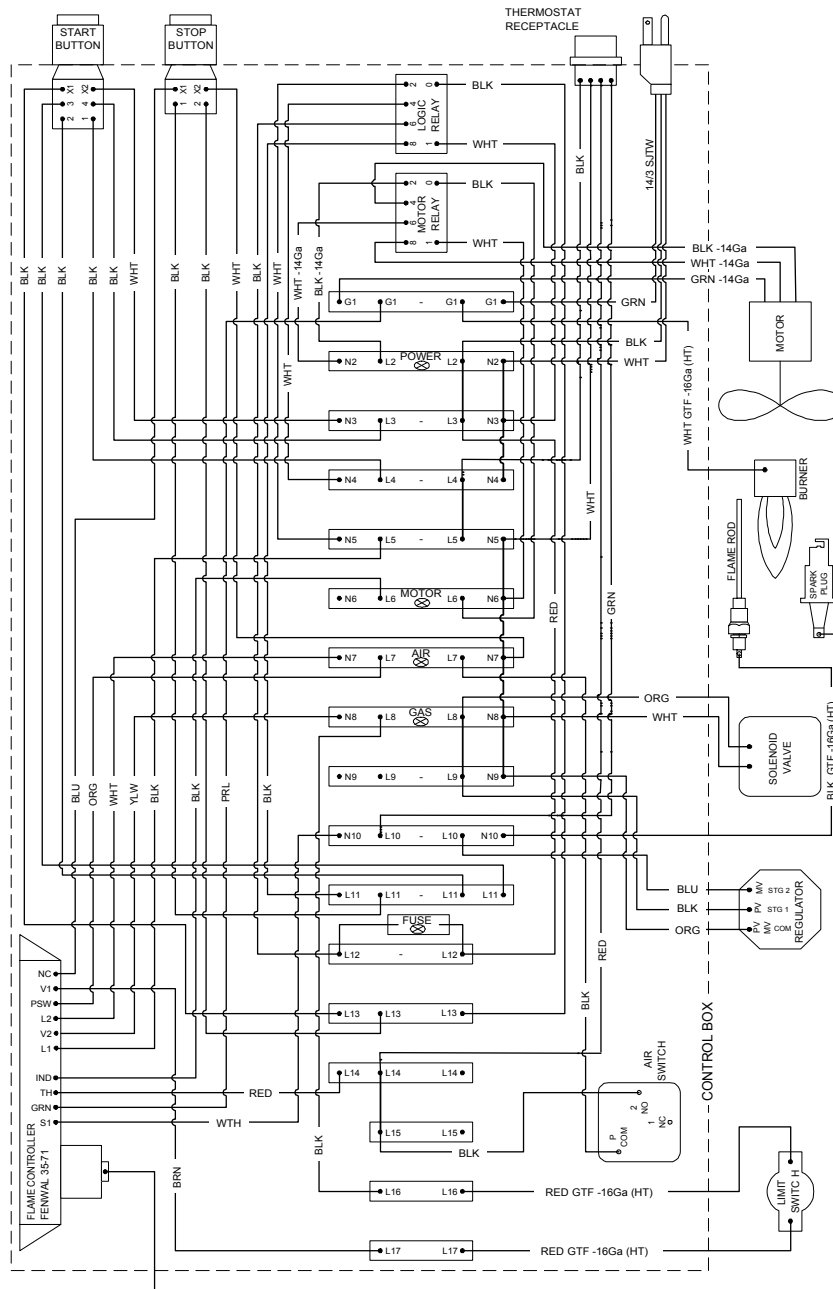

Note: All wires 18 Ga STR TEW 600V unless otherwise specified.

Rev 2.1 From S/N: 8085



# S1500E Ladder Wiring Diagram

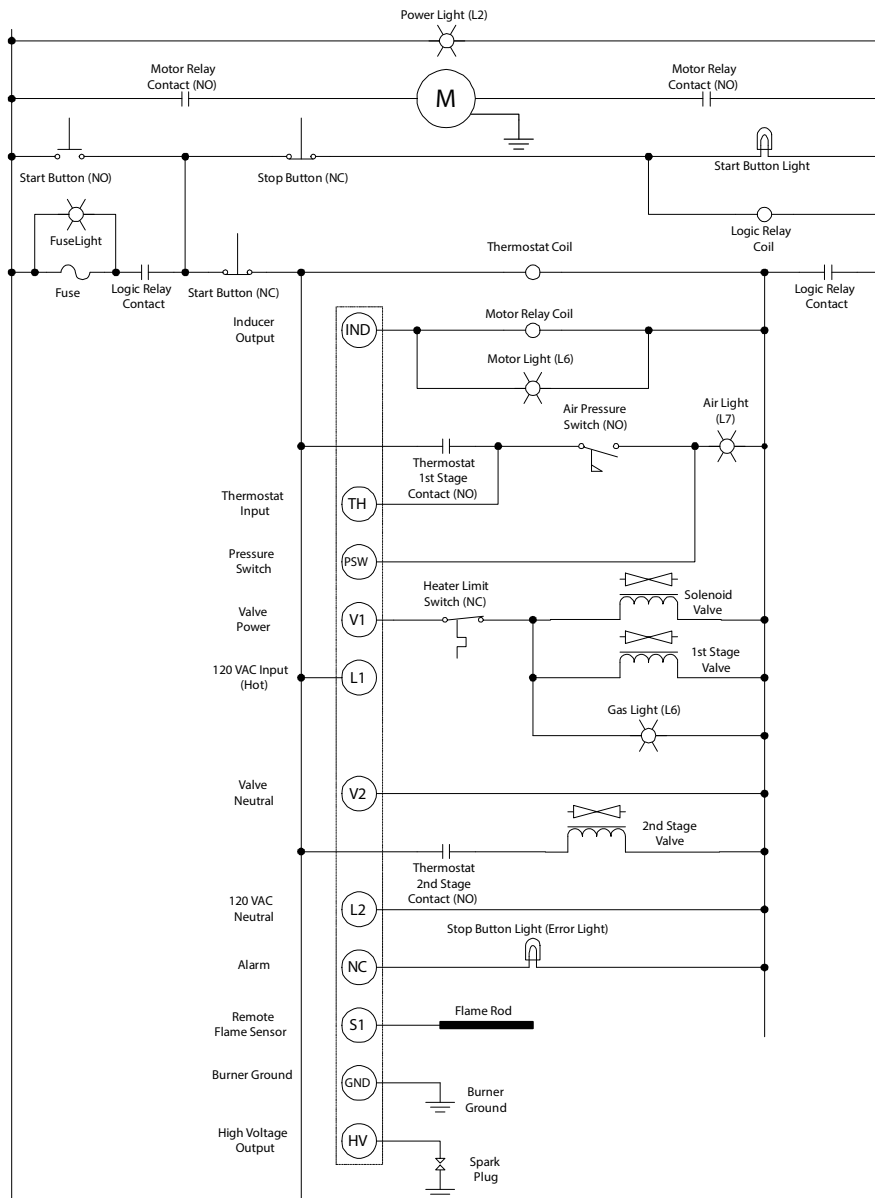

## Two-Stage Thermostat Wiring Diagram (S1500-714)

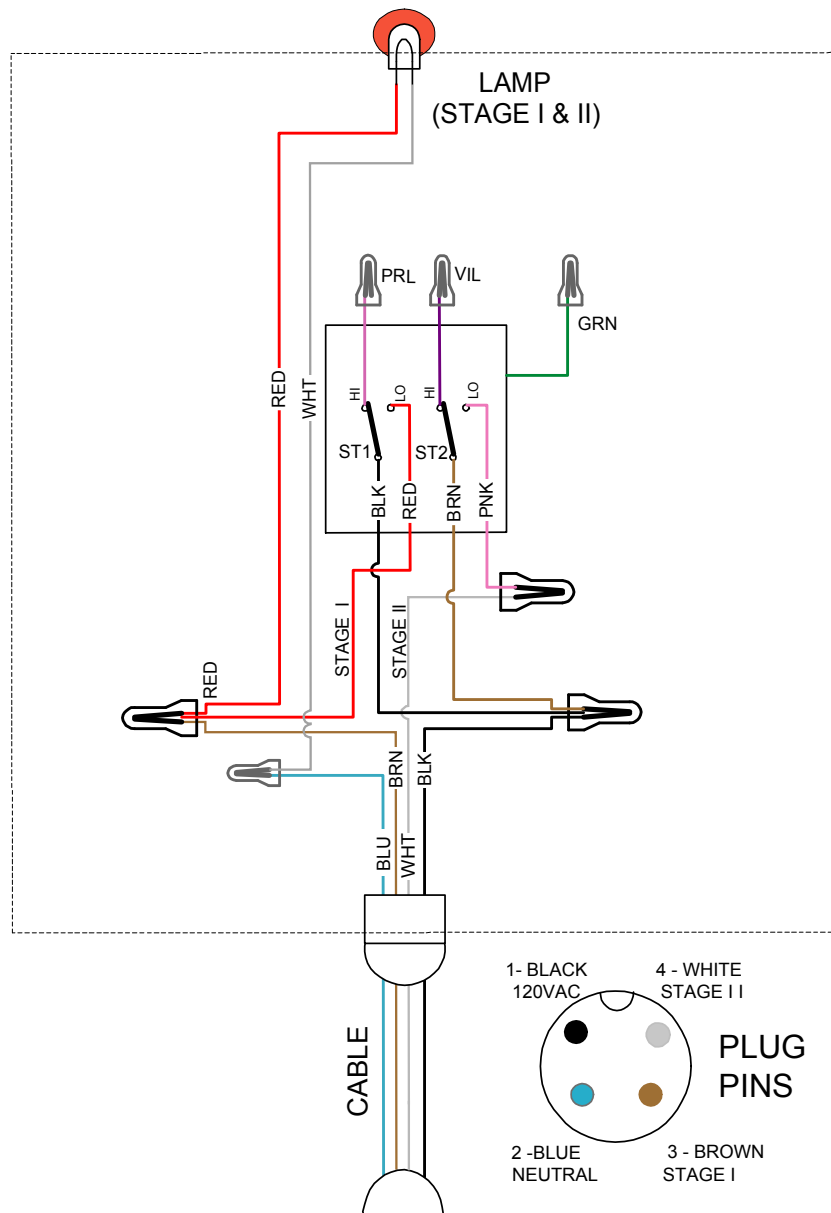

## LPG - PROPANE FUEL VAPORIZATION RATE

The following chart shows the amount of BTU's that various sizes of tanks will produce on the average at specific temperatures and regular atmospheric conditions.

Tank Size Gallons (Pounds)	Maximum intermittent withdrawal rate (BTU/hr) without tank frosting* if lowest outdoor temperature (average for 24 hours) reaches.							
	+40 F.	+30 F.	+20 F.	+10 F.	0 F.	-10 F.	-20 F.	-30 F.
150 (600)	214,900	187,900	161,800	148,000	134,700	132,400	108,800	107,100
250 (1000)	288,100	251,800	216,800	198,400	180,600	177,400	145,800	143,500
500 (2000)	478,800	418,600	360,400	329,700	300,100	294,800	242,300	238,600
1000 (4000)	852,800	745,600	641,900	587,200	534,500	525,400	431,600	425,000

\* Frosting on the outside of the tank acts as an insulator, reducing the vaporization rate.

## MAXIMUM BTU CONTENT (PROPANE)

The following table shows the maximum BTU's that a cylinder contains.

CYLINDER SIZE	BTU CONTENT
100 pound	2,159,100
250 gallon USA	22,922,500
500 gallon USA	45,845,000
1000 gallon USA	91,690,000

**CAUTION:** In extremely cold weather it is impossible to completely empty a propane cylinder.

## PRESSURE & FLOW EQUIVALENTS

1 Std. Atmosphere =	14.73 lb./sq. in. =	1.014 bar
1" Water Column (W.C.) =	0.58 oz./sq. in. =	2.49 millibar
11" Water Column =	0.4 lb./sq. in. =	27.39 millibar
1 lb./sq. in. (psig) =	27.71" W.C. =	0.0689 bar
1" Mercury =	0.49 psig =	33.86 millibar
1 Std. Cubic Ft./Hr. =	2,500 BTU/Hr. =	0.02832 cu. m/hr.
1 BTU/Hr. =	0.2931 Watts	