

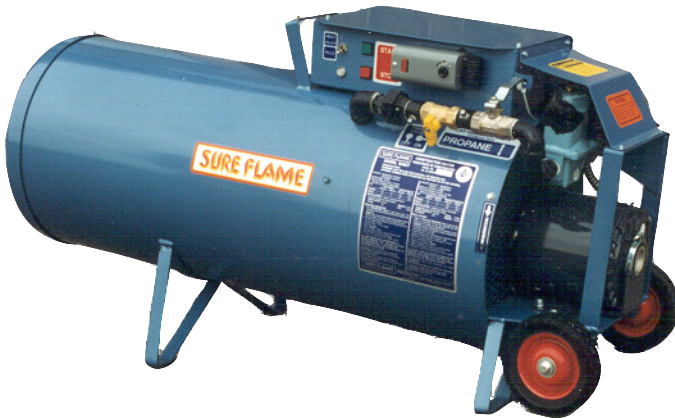

**SURE FLAME<sup>®</sup>**

**S405**

**CONSTRUCTION HEATER**



August 12, 2002

**SERVICE AND MAINTENANCE MANUAL No. 934-5731**  
**PLEASE RETAIN FOR FUTURE REFERENCE**

**SURE FLAME<sup>®</sup> PRODUCTS**

A DIVISION OF HAUL-ALL EQUIPMENT LTD.  
LETHBRIDGE, ALBERTA



# S405 CONSTRUCTION HEATER



## GENERAL HAZARD WARNING

Failure to comply with the precautions and instructions provided with this heater, can result in death, serious bodily injury and property loss or damage from hazards of fire, explosion, burn, asphyxiation, carbon monoxide poisoning, and/or electrical shock.

Only persons who can understand and follow the instructions should use or service this heater.

If you need assistance or heater information such as an instruction manual, labels, etc. Contact the manufacturer.



## WARNING

Fire, burn, inhalation, and explosion hazard. Keep solid combustibles, such as building materials, paper or cardboard, a safe distance away from the heater as recommended by the instructions. Never use the heater in spaces which do or may contain volatile or airborne combustibles, or products such as gasoline, solvents, paint thinner, dust particles or unknown chemicals.



## WARNING

Not for home or recreational vehicle use

# READ THIS WARNING FIRST !

The heater is designed and approved for use as a construction heater under ANSI Z83.7-2000 Construction Heater. The primary purpose of construction heaters is to provide temporary heating of buildings under construction, alteration, or repair and to provide temporary emergency heat. Properly used the heater provides safe economical heating. Products of combustion are vented into the area being heated.

The heater is not designed as an Unvented Gas Fired Room Heater under ANSI-Z21.11.2 and should not be used in the home.

ANSI A119.2(NFPA 501C)-1987 Recreational Vehicle Standard prohibits the installation or storage of LP-Gas containers even temporarily inside any recreational vehicle. The Standard also prohibits the use of Unvented Heaters in such vehicles.

## **NFPA-58 1989 STANDARD FOR THE STORAGE AND HANDLING OF LIQUEFIED PETROLEUM GASES**

Use of the heater must be in accordance with this Standard and in compliance with all governing state and local codes. Storage and handling of propane gas and propane cylinders must be in accordance with NFPA 58 and all local governing codes.

We cannot anticipate every use which may be made for our heaters. **CHECK WITH YOUR LOCAL FIRE SAFETY AUTHORITY IF YOU HAVE QUESTIONS ABOUT LOCAL REGULATIONS.**

Other standards govern the use of fuel gases and heat producing products in specific applications. Your local authority can advise you about these.

# S405 CONSTRUCTION HEATER

## FOR YOUR SAFETY

**DO NOT USE THIS HEATER IN A SPACE WHERE  
GASOLINE OR OTHER LIQUIDS HAVING  
FLAMMABLE VAPOURS ARE STORED OR USED.**

### CONTENTS:

Specifications .....	6
Installation .....	7
Installation Using a Propane Supply Cylinder .....	8
Installation for Natural Gas Applications .....	8
Operating Instructions .....	9
Heater Parts .....	10
Common Installation and Operational Problems .....	12
Safety Features .....	12
Design Related Additional Safety Features .....	13
On-Site Safety Problems .....	13
Preventive Maintenance .....	14
Trouble Shooting .....	15
S405 Connection Wiring Diagram .....	16
S405 Schematic Wiring Diagram .....	17

# S405 SPECIFICATIONS

Certified to ANSI Z83.7-2000 Construction Heater

Gases: Natural or Propane

Capacity: 400,000 Btu/h maximum

Orifice Size: 42 DMS (x18)

Blower: 2,000 cfm

Electrical Rating: 115 volts, 60 Hz, 12 amps, single phase

Minimum Temperature Rating: Minus 40 degrees F

Gas Supply:	Inlet Pressure		Manifold Pressure
	Max W.C.	Min W.C.	W.C.
Propane	14 inches	7 inches	1.3 inches
Natural	14 inches	7 inches	4.0 inches

(Minimum inlet pressure is for purpose of input adjustment)

# INSTALLATION

The Sure Flame Model S405 is a direct fired gas heater intended to be used primarily for the temporary heating of buildings under construction, alteration, or repair. Since all the products of combustion are released into the area being heated, it is imperative that adequate ventilation is provided. The flow of supply air and combustion gases must not be obstructed in any way. Do not use the heater with ductwork as this will restrict the flow of supply air.

- 1 Install the heater properly in a horizontal position at least 10 ft. (3 m) from any propane-gas container. Front Outlet must not be directed toward any propane-gas container within 20 ft. (6 m). Allow the following clearances from any combustible material:

Front Outlet:	12 feet	Sides:	2 feet
Intake:	2 feet	Top:	5 feet

Also make sure that no flammable vapours are present in the space where the heater is being used.

- 2 When connecting the heater to a natural gas or propane supply line ensure that the pressure at the heater inlet is within the specified range. Please refer to Propane and Natural Gas Installation sections in this manual. Excessive pressure (over 1/2" psig) will damage the controls and void the warranty.
- 3 Visually inspect the hose assembly and ensure that it is protected from traffic, building materials, and contact with hot surfaces. If it is evident that there is excessive abrasion or wear, or the hose is cut, it must be replaced.
- 4 After installation, check the hose assembly for gas leaks by applying a water and soap solution to each connection.
- 5 Connect the heater to an adequate 115 volt electrical supply and in compliance with the *Natural Electrical Code ANSI/NFPA 70*. For protection against shock hazard the supply cord should be plugged directly into a properly grounded three-prong receptacle.
- 6 In all applications install the heater in such manner it is not directly exposed to water spray, rain and/or dripping water.

# INSTALLATION USING A PROPANE SUPPLY CYLINDER

- 1 When installing the heater for use with propane gas, set the gas selector valve to “Propane” and lock in position.
- 2 The supply container **MUST** be equipped with an LP Gas Regulator that complies with ANSI/UL 144 Standard for Pressure Regulating Valves for LP Gas. Another regulator must be installed on the heater to reduce the pressure from this regulator down to a maximum inlet pressure of 1/2 psi.
- 3 Arrange the cylinder supply system to provide for vapour withdrawal from the operating cylinder. Supplying liquid propane to the heater is dangerous and will damage the components.
- 4 Ensure that for the surrounding temperature, the size and capacity of the propane supply cylinder is adequate to provide the rated Btu/h input to the heater.
- 5 Turn off the propane supply valve at the cylinder when the heater is not in use.
- 6 The installation must conform with all local codes, or in the absence of local codes, with the Standard for the *Storage and Handling of Liquefied Petroleum Gases, ANSI/NFPA 58.*
- 7 When the heater is to be stored indoors, the propane cylinder(s) must be disconnected from the heater and the propane cylinder(s) removed from the heater and stored in accordance with the National Standard for the *Storage and Handling of Liquefied Petroleum Gases, ANSI/NFPA 58.*

## INSTALLATION FOR NATURAL GAS APPLICATIONS

- 1 When installing the heater for use with natural gas, set the GAS SELECTOR VALVE to the “Natural” position.
- 2 A regulator must be installed on the heater to ensure that the pressure to the heater does not exceed 1/2 psi (14" W.C.) inlet pressure.
- 3 The installation of this heater to a natural gas supply must conform with all applicable local codes or, in the absence of local codes, with the *National Fuel Gas Code ANSI Z223.1/NFPA 54.*



# OPERATING INSTRUCTIONS

- 1 Set GAS SELECTOR VALVE to gas being used. The conversion shall be done by the owner or lessor of the equipment.

**NOTE:** When using Propane Gas the Selector Valve **MUST** be locked in position.

- 2 Ensure the MANUAL VALVE (valve nearest the burner) is in the “ON” position.
- 3 Connect power - 115 volt supply.
- 4 Open gas supply.
- 5 Push and hold START button **for five seconds**.
- 6 Set thermostat to desired temperature.
- 7 To stop, turn gas off.

The appliance area should be kept clear and free from combustible materials, gasoline, and other flammable vapours and liquids.

Ensure that the flow of supply air and combustion gases is not obstructed.

The installation and operation of the heater shall comply with the code requirements specified by the authorities having jurisdiction.

General criteria for the use of construction heaters may be found in the applicable sections of American National Standard A10.10-1987, Safety Requirements for Temporary and Portable Space Heating Devices and Equipment Used in the Construction Industry.

## **INSTALLATION AND MAINTENANCE OF THE HEATER MUST BE ACCOMPLISHED BY A QUALIFIED SERVICE PERSON**

**NOTE: S405 HEATERS WITH SERIAL NUMBER 5437  
AND GREATER, WILL HAVE A 3.3 SECOND DELAY  
BEFORE STARTING.**

# S405 HEATER PARTS

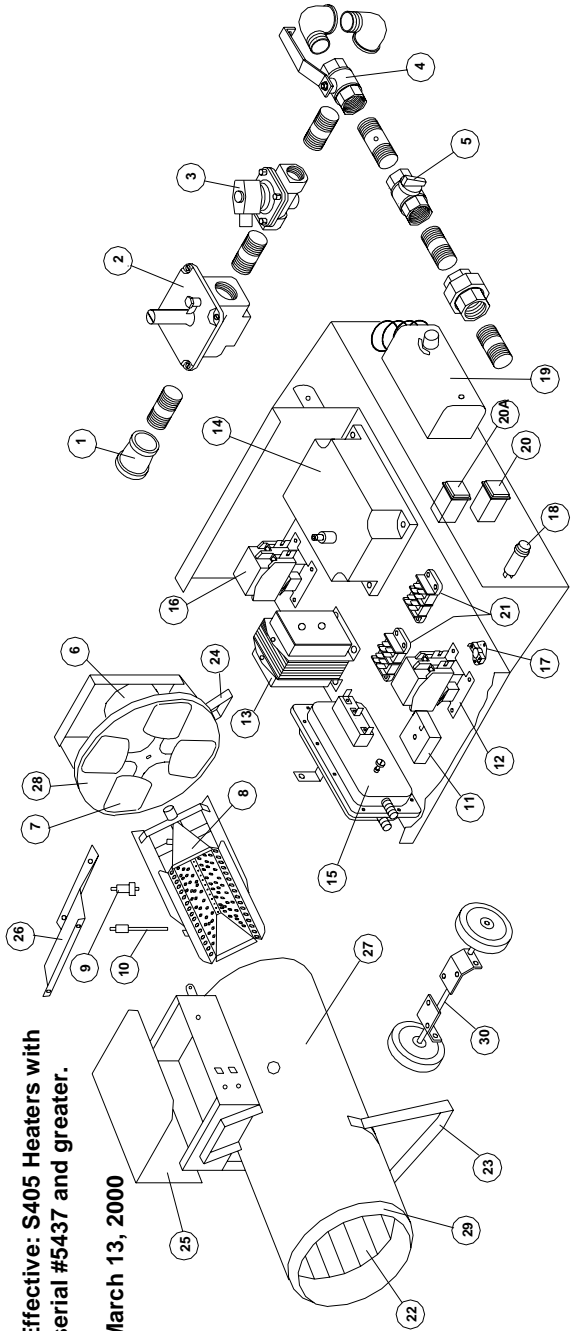

Effective: S405 Heaters with serial #5437 and greater.

March 13, 2000

# S405 HEATER PARTS

Aug. 12, 2002

Ref.	Part No.	Description
1	S400-80	Strainer
2	2524	Low Pressure Regulator
3	4514	Solenoid Shut Off Valve 24V
4	S400-73	S400 Changeover Valve
5	5869	Manual Shut Off Valve
6	2430	Motor 1/4 H.P.
7	2420	Fan Blade
8	BV45-50	Burner
9	2143	Spark Plug
10	S400-86	Flame Rod
11	7465	24VAC 5-Second Delay-ON-Break Timer
12	4519	Control Relay 24V
13	4510	Transformer 24V
14	8264	Direct Spark Ignition Control
15	5124	Air Switch
16	4519	Motor Relay 24V
17	2446	180 Deg. High Limit Thermostat
18	4518	Indicator Light 24V
19	2453	Thermostat
20	3337/8	OFF Switch (Red)
20A	3337/9	ON Switch (Green)
21	5768	Terminal Block
22	S400-16	Heat Shield
23	S400-57	Front Leg Assembly
24	S400-47	Rear Leg Assembly (less motor mount & screen)
25	S400-7	Control Box Lid
26	S400-103	Valve Train Cover
27	S400-503	Heater Body Includes 22, 23, 29
28	S400-502	Motor Mount (with screen & rear legs)
29	S400-3	Nose Cone
30	S400-81	Wheel Kit (optional)

# COMMON INSTALLATION & OPERATIONAL PROBLEMS

- 1 **LOW VOLTAGE** - This is one of the most common problems and is usually the result of the supply cord having too small a wire gauge for its length. Low voltage results in the motor overheating, burnt relay contacts, or a relay that will not make contact.
- 2 **SUPPLY LINE TOO SMALL**
- 3 **INSUFFICIENT VAPORIZATION AT SUPPLY** - Normally caused by too small size of supply tank.
- 4 **IMPROPER GAS SUPPLY PRESSURE** - Usually a result of supply pressure being too high because of improper or lack of regulation.
- 5 **DIRTY GAS SUPPLY** - Dirty gas can cause strainers to plug or form a build-up in the burner orifice.
- 6 **LACK OF PREVENTATIVE MAINTENANCE** - Heaters must be cleaned as required, especially when used in a dirty environment.
- 7 **IMPROPER SUPPLY OF FRESH AIR** - It is normally recommended that the intake air of the heater be taken from outside the enclosed area. This provides a slight pressurization and prevents any problems associated with recirculation.

## SAFETY FEATURES

Servicing of Sure Flame Construction Heaters normally involves one of several built-in safety features. The Model S405 incorporates devices to detect the following:

- |                             |   |
|-----------------------------|---|
| 1 <b>LOSS OF FLAME</b>      | Gas supply is shut off if flame is lost to prevent raw gas from leaving the heater.                             |
| 2 <b>OVERHEATING</b>        | (a) Thermal overload protection in the motor.<br>(b) High temperature limit switch in the combustion chamber.   |
| 3 <b>LOSS OF POWER</b>      | Total shutdown with manual reset required. Any one of the safety devices will create a loss of power situation. |
| 4 <b>BLOCKED AIR SUPPLY</b> | A switch detects the differential pressure in the combustion chamber and shuts down when insufficient.          |

# **DESIGN RELATED ADDITIONAL SAFETY FEATURES:**

## **1 LOCKING POSITION FOR LPG ON GAS SELECTOR LEVER**

Units used with LPG while the gas selector valve is positioned for Natural Gas will throw significantly more heat than the rated Btu/h. This is definitely a safety hazard.

## **2 LOW SKIN TEMPERATURE**

Sure Flame Heaters are designed to have a low skin temperature. This provides added safety in the workplace.

## **3 DURABLE CONSTRUCTION**

The Model S405 uses a stainless steel burner for long life and consistent performance.

In order to maintain the highly efficient combustion of the Sure Flame Heater, the combustion chamber must remain as manufactured. Any change or distortion could alter the fuel/air mixture and create unwanted gases.

# **ON-SITE SAFETY PROBLEMS**

## **1 SHORTING OUT OF DEFECTIVE COMPONENTS**

This is a very common problem which saves short term expense at the risk of a large future cost. Any heaters found in this condition should be removed immediately.

## **2 IMPROPER ENCLOSURES**

When heaters are installed partially to the outside for fresh air intake, strict adherence must be made to the minimum clearance to combustibles given on the instruction plate. Wood framing around a heater is a hazard and should not be used.

## **3 SUPPLYING LIQUID PROPANE TO HEATER**

This heater is not intended to burn liquid propane. To minimize the damage, shut off the gas supply and let the heater run until all of the liquid in the lines has been burnt.

# PREVENTATIVE MAINTENANCE

Sure Flame Construction Heaters are built to withstand the rigours of operating on construction sites, mining applications, and a multitude of other locations where heaters are used. To maintain reliable performance it is necessary to perform regular maintenance.

## A VISUAL CHECKS

The following items should be checked for excessive wear or damage:

- 1) Wheels (if installed)
- 2) Cords and Connectors
- 3) Wiring and Conduit
- 4) Heater Shell (including heat shield) and Control Box

It is recommended that units be purchased as spares be rotated periodically, so that each unit will be placed in operated at least every 90 days.

## B BURNER

Flame Rod and Insulator - Clean with soap and water or solvent on a routine basis. Any build up on burner should also be removed at this time.

Spark Plug - Clean with solvent and check spark gap.

C CONTROL BOX - The inside of the control box should be cleaned using a dry cloth or by blowing compressed air. Do not use any liquid or aerosol spray cleaners. Also check that all electrical connections are snug and tight.

D MOTOR - The electric motor on the S405 Heater is fitted with sealed bearings and no oiling is required. Keep the motor clean by blowing or wiping off dust or dirt in order to prevent it from over heating.

E FAN - Check for dust or dirt build up on fan blades. Check the tightness of the set screw and run the heater to check for fan vibration.

# S405 TROUBLE SHOOTING CHART

SEQUENCE

PROBLEM

CHECK

CAUSE

Sept 27, 1989

SEQUENCE	PROBLEM	CHECK	CAUSE
1	Press START Power relay closes indicated by a "Click" sound (adjust thermostat clockwise for S405 & S400T OFF/ON model only)	- If no power between L1, L2 - If no power at limit switch - If no power at transformer - If no power at relay coil - If power at relay coil	No power at plug Faulty stop/start switch Faulty limit switch Faulty ignition control Faulty relay
	Fan motor starts	- If no power between T1, T2 - If power between T1, T2	Faulty relay contacts Faulty motor
2.	Ignition control produces spark	- If power between POWER & GND on ignition control - If NO power between POWER & GND on ignition control	Faulty ignition control or spark plug. Faulty transformer
	Short delay until fan reaches full RPM Air Switch closes Safety shut-off gas valve opens indicated by "Click" sound	- If NO power at air switch pressure differential to close air switch or faulty air switch - If power at air switch	Insufficient air
3.	Gas ignites, flame is proven,	- Recheck sequence #2 Check gas supply	Faulty solenoid Insufficient gas pressure.
4.	Light ON	- Press STOP Button to reset return to Sequence #1 above	
	Thermostat controlled operation on S400T (HI/LO)	- If NO power at hi fire valve not close	Faulty thermostat or setting too high

# S405 CONNECTION WIRING DIAGRAM

March 13, 2000

NOTE: This wiring diagram applies to heaters with S/N #5437 and greater.

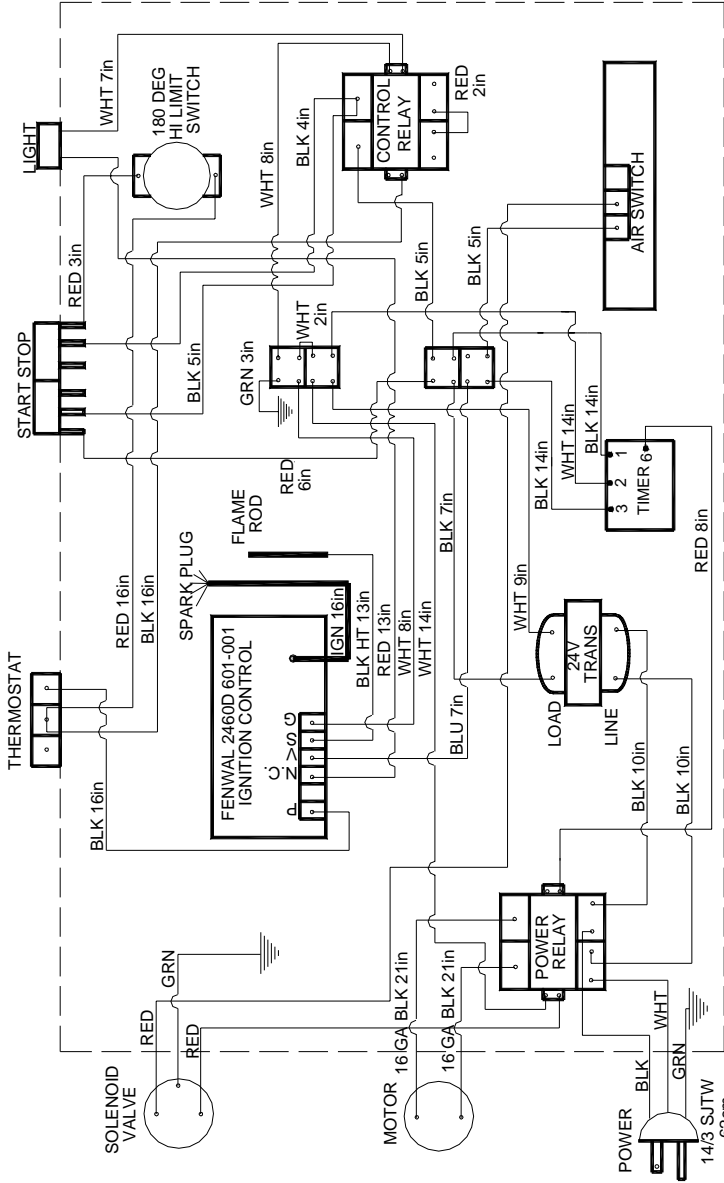

NOTE: ALL WIRES 18 GA STR TEW 600V UNLESS OTHERWISE SPECIFIED



# S405 LADDER WIRING DIAGRAM

